

Installation, Operation, Maintenance: MV/MVH TERMINAL

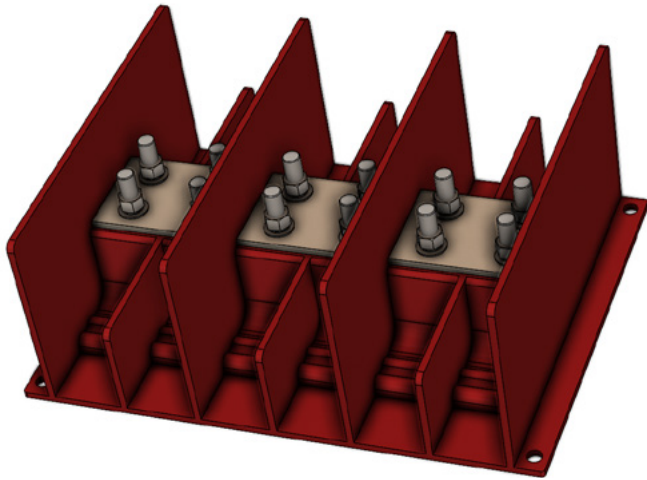

Certification Details

ATEX:	ABTECH Ltd.	CML 15ATEX3096U
UKEX:	ABTECH Ltd.	CML 23UKEX3297U
IECEX:	ABTECH Ltd.	IECEX CML 15.0051U

	MVx	MVxT	MVHx/300A	MVHx/600A
Max. voltage	Up to 4.4kV*	Up to 6.6kV*	8.8kV	8.8kV
Max. current	250A	250A	300A	600A
Max. conductor size	Up to 240mm ² *	Up to 240mm ² *	240mm ²	240mm ²

*Refer to MV and MV*T voltage and conductor size limitations in the instructions below.

NOTE: The ABTECH MV and MVH terminal is delivered as an assembly for securing inside an Ex e component certified enclosure. The only removable parts are the crimp lug securing studs, nuts and washers and the current bar. The stud thread size is M8, M10 or M12 with nuts which are 13mm, 17mm or 19mm respectively across flats. Crimp lugs must be suitable for this stud size. **The removal or disassembly of any other parts may render the certification void.**

Equipment

Crimp lugs suitable for the conductor size, with palm hole suitable for M8/M10/M12 studs.

A socket, suitable for use with nuts which are 13mm/17mm/19mm across flats.

A socket driving device with torque measurement including the range 6Nm to 12Nm.

Installation Instructions for MVx / MVxT

Ensure that the selected crimp lugs have a palm hole suitable for the stud size fitted.

The terminal assembly must be secured using 4 off machine screws through the holes provided at the corners of the base plate. It may be secured to a flat chassis plate, either metallic or non-metallic, or located over accurately positioned studs or threaded holes.

The MVx assembly base plate must not be mounted closer than 5mm from the enclosure wall. For MVxT (tall barrier) assemblies the minimum permitted distance is 10mm.

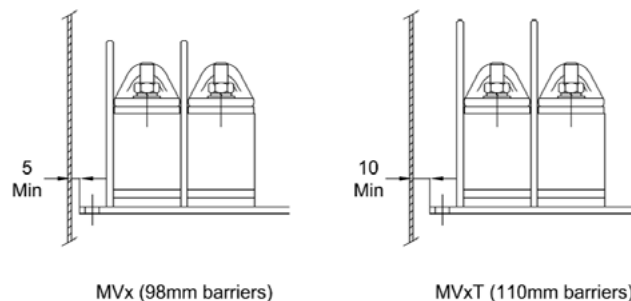

Once secured, prepare the cable conductors by stripping the insulation to suit the crimp lug and then crimp the lug securely to the conductor. Take care to orientate the crimp lug with the intended terminal stud current bar to minimise externally applied torque.

Note: the crimping device and die set must be suitable for use with the selected crimp lugs. It is the installer's responsibility to ensure that the completed crimp meets the requirements of BS EN 61238-1:2003 (or IEC 61238-1:2003 or equivalent local national standard) by the use of appropriate equipment.

Installation, Operation, Maintenance: MV/MVH TERMINAL

Remove the terminal stud nut and washers, but NOT the current bar, and locate the crimp lug over the stud, placing it on top of the current bar.

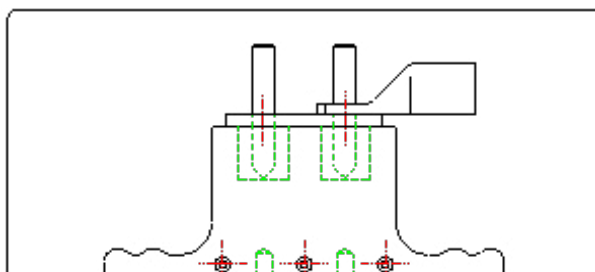

Replace the flat washer, then the spring washer and then the nut, initially tightening by hand. Using the socket and driving device, secure the retaining nut to the following values:

Stud Size	Torque (Nm)
M8 (standard option)	6 to 12
M10	17.5 to 19.5
M12	30 to 34

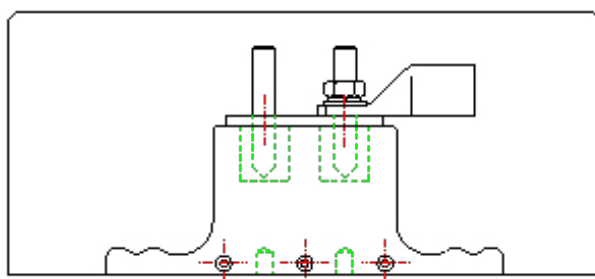

Repeat these steps for all remaining conductors.

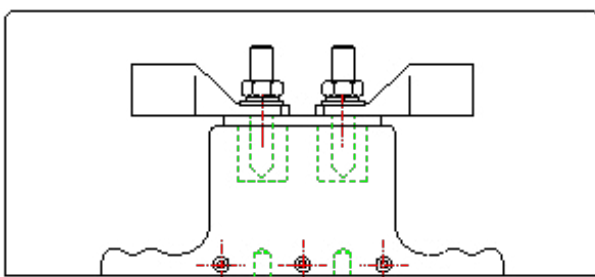

The maximum operating voltage of the MV terminal is limited by the conductor size as follows:

Maximum conductor size (mm ²)	Maximum operating voltage (kV) MVx (98mm barriers)	Maximum operating voltage (kV) MVxT (110mm)
240	3.52	5.50
≤185	4.40	6.60

Installation, Operation, Maintenance: MV/MVH TERMINAL

In the event that two cables are to be connected to the same stud the arrangements shown below are permitted.

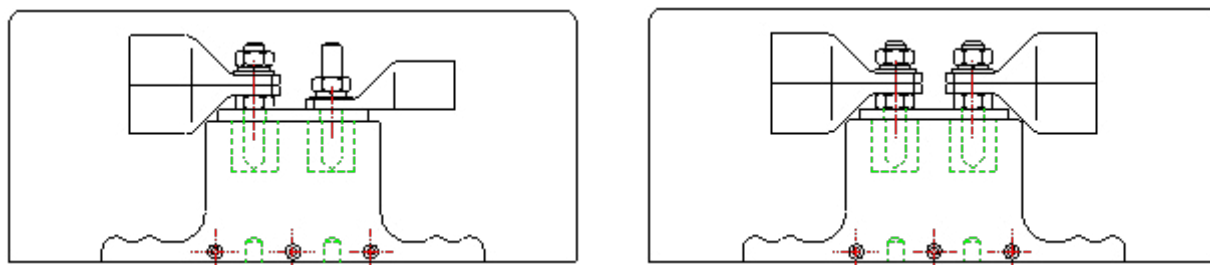

Typical arrangement for multiple lugs. A maximum of 4 single hole lugs may be fitted per way.

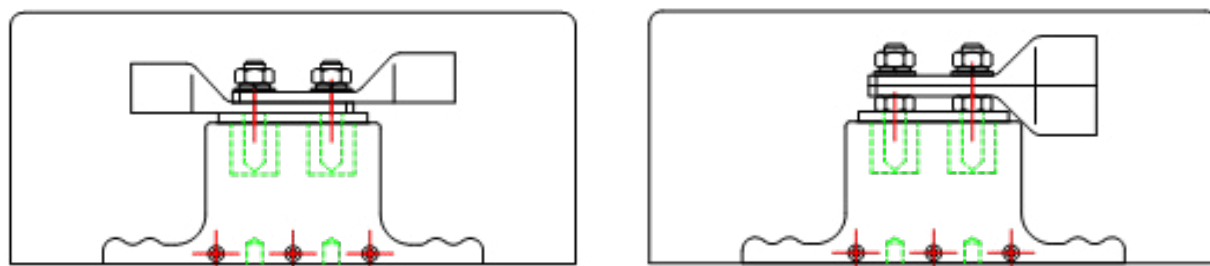

A maximum of 2 x 2-hole lugs may be fitted per way. Typical layouts shown.

When such stacked lug arrangements with MV terminal are used, further limits on the maximum permitted voltage apply as follows:

Maximum conductor size (mm ²)	Maximum operating voltage (kV) MVx (98mm barriers)	Maximum operating voltage (kV) MVxT (110mm barriers)
240	2.20	4.40
185	2.75	4.40
150	3.52	5.50
120	3.52	5.50
95	3.52	5.50
≤70	4.40	6.60

Installation, Operation, Maintenance: MV/MVH TERMINAL



Installation Instructions for MVHx

Ensure that the selected crimp lugs have a palm hole suitable for the stud size fitted.

The terminal assembly must be secured using 4 off machine screws through the holes provided at the corners of the base plate. It may be secured to a flat chassis plate, either metallic or non-metallic, or located over accurately positioned studs or threaded holes.

The MVHx terminal assembly base plate must not be mounted closer than 20mm from the enclosure wall, ensuring a minimum distance of 41mm from the enclosure wall to the end plates. There must be at least 85mm clearance from top of largest lug to underside of enclosure wall or door.

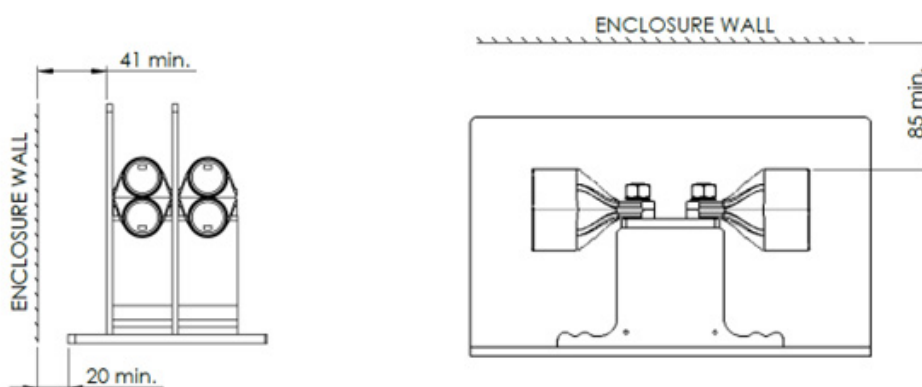

Once secured, prepare the cable conductors by stripping the insulation to suit the crimp lug and then crimp the lug securely to the conductor. Take care to orientate the crimp lug with the intended terminal stud current bar to minimise externally applied torque.

Note: the crimping device and die set must be suitable for use with the selected crimp lugs. It is the installer's responsibility to ensure that the completed crimp meets the requirements of BS EN 61238-1:2003 (or IEC 61238-1:2003 or equivalent local national standard) by the use of appropriate equipment.

Remove the terminal stud nut and washers, but NOT the current bar, and locate the crimp lug over the stud, placing it on top of the current bar.

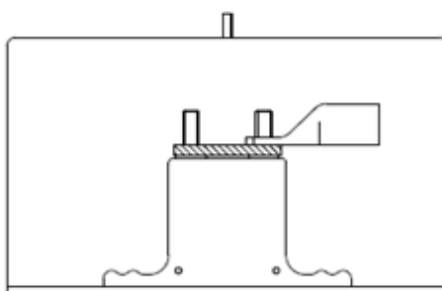

Replace the flat washer, then the spring washer and then the nut, initially tightening by hand. Using the socket and driving device, secure the retaining nut to the following values:

Stud Size	Torque (Nm)
M8	6 to 12
M10 (standard option)	17.5 to 19.5
M12	30 to 34

Installation, Operation, Maintenance: MV/MVH TERMINAL

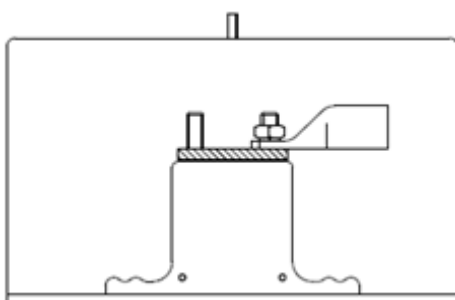

Repeat for all remaining conductors and secure the acrylic cover with the M6 nylon nuts.

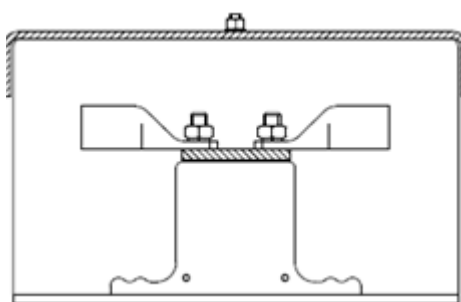

The maximum operating voltage of the MVH terminal is 8.8kV. There are no restrictions based on cable size for the MVH terminal.

In the event that two cables are to be connected to the same stud the arrangements shown below are permitted.

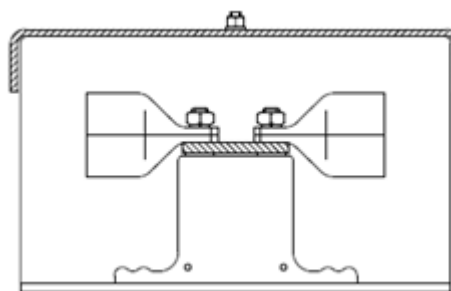
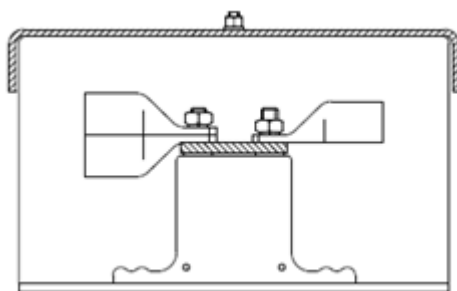

Typical arrangement for multiple lugs. A maximum of 4 single hole lugs may be fitted per way.

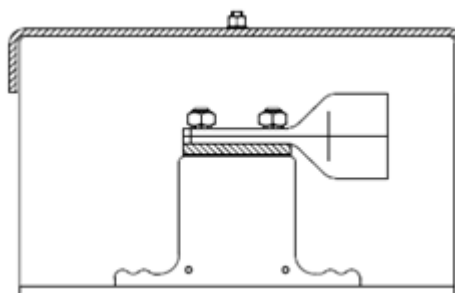
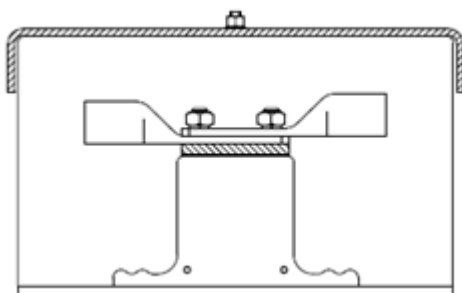

A maximum of 2 x 2-hole lugs may be fitted per way. Typical layouts shown.

When stacked lug arrangements with MVH terminal are used, there are no restrictions based on cable size or arrangement.

Conditions of Use

The following conditions relate to safe installation and/or use of the equipment.

- i. The terminal assembly shall be installed in a suitably approved enclosure with a minimum of IP54.
- ii. When incorporated into equipment, the terminals shall be suitably installed so as to be protected from mechanical strain from the cables pulling.
- iii. The service temperature range of the terminals is -40°C to +130°C
- iv. No more than four (4) "single hole cable lug" and no more than two (2) "2-hole cable lugs" may be fitted per way.

Applicable Standards

ATEX/UKEX: EN 60079-0:2018, EN 60079-7:2015+A1:2018

IECEx: IEC 60079-0:2017, IEC 60079-7:2017

Chemical Attack

The following materials are used to manufacture the ABTECH MV Terminal range – GRP, brass, tinned copper, 316 stainless steel, acrylic and nylon.

Consideration should be given to the environment in which the unit is to be used to determine the suitability of these materials to withstand any corrosive agents that may be present.